

AMERICAN CART & RACK

MANUFACTURED BY GRANITE INDUSTRIES

67500-12
STORAGE RACK WITH 65" LEGS
AND STEEL WHEELS



3000 LB



OUR CARTS
HAUL
MORE

PROUDLY
MADE IN THE
USA



BUILT
HEAVY DUTY
TO OUTLAST
OTHERS



THREE
YEAR
LIMITED
WARRANTY

FEATURES

- 8" steel casters: 2 locking swivel, 2 fixed
- Stack up to 3 high, do not exceed 3,000 lbs on casters
- Eight E-Track ratchet strap mounts (optional e-straps: PI-11-0212)
- Removable legs for easy loading and unloading
- Removable caps allow racks to fit into trailers
- Holds up to:
 - 15 - 8' crowd control fence panels
 - 135 - polyfold chairs

STANDARD AMERICAN CART FEATURES

- **Made in the USA**
Hand crafted at our Ohio plant.
- **Heavy-duty comes standard**
American Carts are all built to heavy duty specs
- **Powder coated finish**
Protects the steel and provides a lasting finish
- **Steel construction**
Built from American sourced steel
- **Easy to operate**
Designed to get work done with less muscle strain and simple operation.
- **Ready to ship**
in stock and ready to ship
- **Three Year Limited Warranty**



AMERICAN CART & RACK

MANUFACTURED BY GRANITE INDUSTRIES

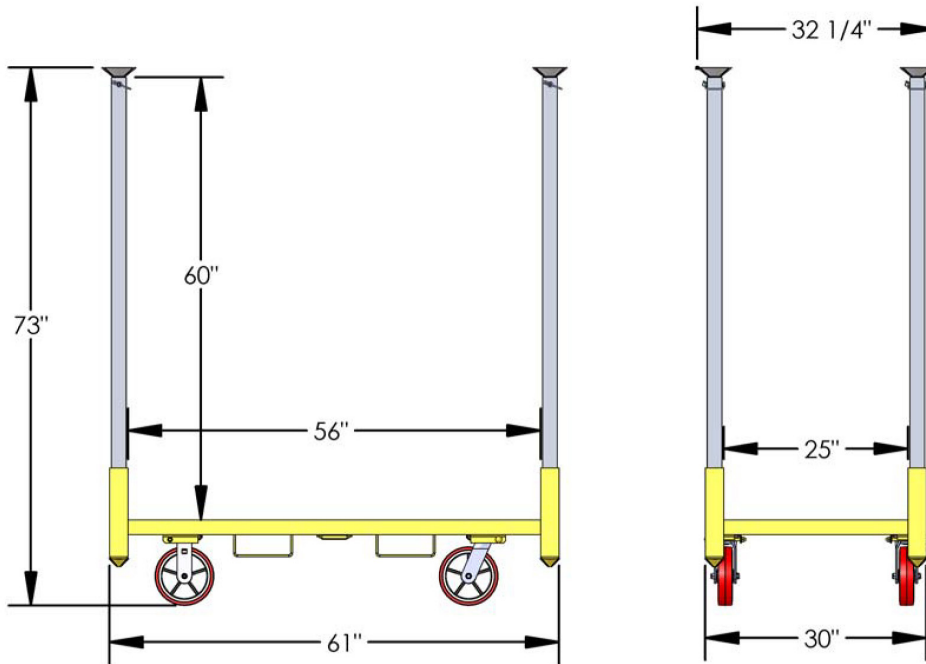

Dimensions:	W: 64"	D: 33"	H: 73"
Inside:	W: 56"	D: 25"	H: 60"
Weight:	192 lb	Capacity:	3,000 lb
Typically Ships:	Freight; minimal assembly required		



Expect more. get more.
FROM GRANITE INDUSTRIES

- Exceptional quality and service on every product.
- Professional grade designs by in house engineers.
- Industry leading warranties.
- Family owned and operated in the USA.

MADE IN THE USA GUARANTEE



Our American made products are engineered, manufactured and assembled in Archbold, OH using USA made steel.



**GRANITE
INDUSTRIES**

877-447-2648
graniteind.com
americancartandrack.com

Scan the QR code to view more products.

