

AMERICAN CART & RACK

MANUFACTURED BY GRANITE INDUSTRIES

67445 ALUMINUM APPLIANCE CART WITH REAR WHEELS



700 LB



OUR CARTS
HAUL MORE

PROUDLY
MADE IN THE
USA



BUILT
HEAVY DUTY
TO OUTLAST
OTHERS



THREE
YEAR
LIMITED
WARRANTY

FEATURES

- 3/4" axle
- 10" Flat free wheels with high capacity plastic hubs
- Adjustable rear 4" casters
- D-brackets on axle add more stability and strength
- Powder coated steel handle
- Dual integrated 10' auto retracting ratchet straps (2" x 10')
- Rubber bumpers protect your load from scratches
- Dual steel stair-crawlers
- Aluminum construction

STANDARD AMERICAN CART FEATURES

- **Made in the USA**
Hand crafted at our Ohio plant.
- **Heavy-duty comes standard**
American Carts are all built to heavy duty specs
- **Aluminum Construction**
Light weight and durable
- **D-Brackets**
One piece design supports the axle and load better than the competition
- **3/4" Axle**
Industry leading axle size for maximum strength.
- **Easy to operate**
Designed to get work done with less muscle strain and simple operation.
- **Ready to ship**
in stock and ready to ship
- **Three Year Limited Warranty**

RAPTOR
HIGH PERFORMANCE ALUMINUM PRODUCTS



10'L x 2"W auto retracting ratchet strap.

AMERICAN CART & RACK

MANUFACTURED BY GRANITE INDUSTRIES

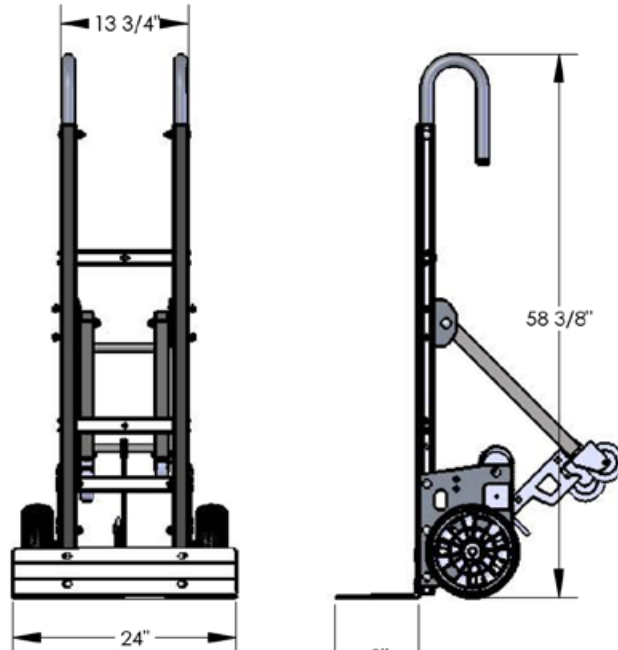

Dimensions:	W: 24"	D: 52"	H: 45"
Foot Plate:	W: 24"	D: 9"	
Weight:	60 lb	Capacity:	700 lb
Typically Ships:	UPS, some assembly required		

*Measurements taken while cart is on 4 wheels



Expect more. get more.
FROM GRANITE INDUSTRIES

- Exceptional quality and service on every product.
- Professional grade designs by in house engineers.
- Industry leading warranties.
- Family owned and operated in the USA.

MADE IN THE USA GUARANTEE



Our American made products are engineered, manufactured and assembled in Archbold, OH using USA made steel.



**GRANITE
INDUSTRIES**

877-447-2648
graniteind.com
americancartandrack.com

Scan the QR code to view more products.

