



660 LB



OUR CARTS
HAUL
MORE

PROUDLY
MADE IN THE
USA



BUILT
HEAVY DUTY
TO OUTLAST
OTHERS



THREE
YEAR
LIMITED
WARRANTY

FEATURES

- 5" Plastic casters; 2 fixed, 2 swivel
- Removable handle
- 40"W x 40"D plywood platform
- 660 lb capacity

STANDARD AMERICAN CART FEATURES

- **Made in the USA**
Hand crafted at our Ohio plant.
- **Heavy-duty comes standard**
American Carts are all built to heavy duty specs
- **Powder coated finish**
Protects the steel and provides a lasting finish
- **Steel construction**
Built from American sourced steel
- **Easy to operate**
Designed to get work done with less muscle strain and simple operation.
- **Ready to ship**
in stock and ready to ship
- **Three Year Limited Warranty**

AMERICAN CART & RACK

MANUFACTURED BY GRANITE INDUSTRIES

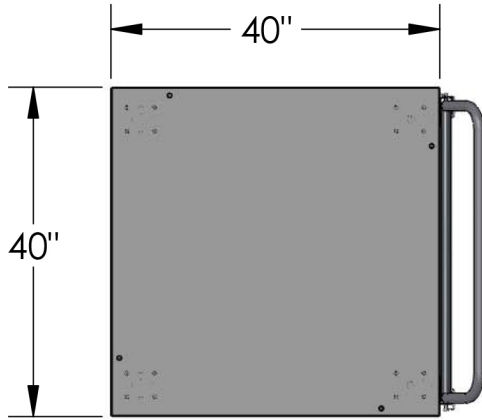

Dimensions:	W: 40"	D: 46"	H: 36"
Weight:	80 lbs.	Capacity:	660 lbs.
Typically Ships:	Freight; minimal assembly required		