

# AMERICAN CART & RACK

MANUFACTURED BY GRANITE INDUSTRIES

67265  
MEGA HAULER WITH  
REAR WHEELS



1,000 LB



OUR CARTS  
HAUL  
MORE

PROUDLY  
MADE IN THE  
USA



BUILT  
HEAVY DUTY  
TO OUTLAST  
OTHERS



THREE  
YEAR  
LIMITED  
WARRANTY

## FEATURES

- Ideal for loose terrain, like sand or gravel
- 3/4" axle
- 16" flotation tires on front
- Adjustable rear 10" flat free wheels
- Welded one piece steel frame
- E-Track ratchet system, 12' E-Strap sold separately (PI-11-0212)
- Oversized footplate (24"W x 12"D)
- 1,000 lb capacity

## STANDARD AMERICAN CART FEATURES

- **Made in the USA**  
Hand crafted at our Ohio plant.
- **Heavy-duty comes standard**  
American Carts are all built to heavy duty specs
- **Powder coated finish**  
Protects the steel and provides a lasting finish
- **Steel construction**  
Built from American sourced steel
- **D-Brackets**  
One piece design supports the axle and load better than the competition
- **3/4" Axle**  
Industry leading axle size for maximum strength.
- **Easy to operate**  
Designed to get work done with less muscle strain and simple operation.
- **Ready to ship**  
in stock and ready to ship
- **Three Year Limited Warranty**



Adjustable wheel position.



Shown with Trailer Dolly 67022-75.

# AMERICAN CART & RACK

MANUFACTURED BY GRANITE INDUSTRIES

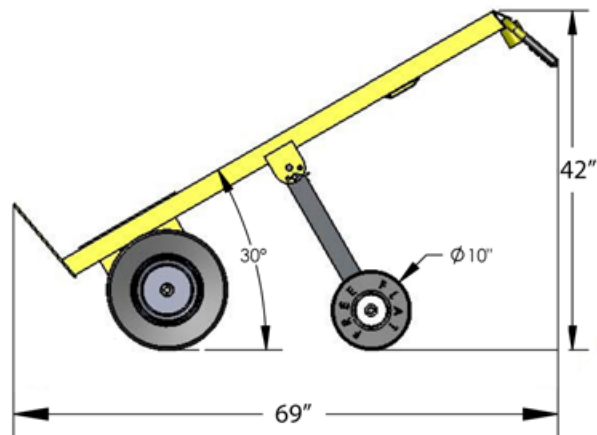
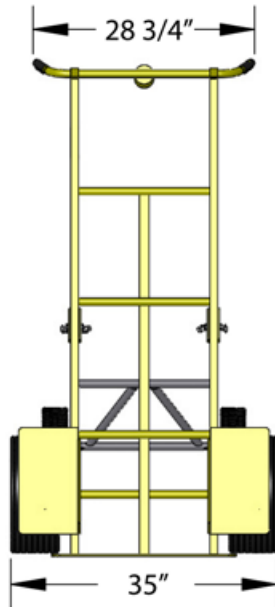

<b>Dimensions:</b>	<b>W:</b> 35"	<b>D:</b> 69"	<b>H:</b> 42"
--------------------	---------------	---------------	---------------

<b>Foot Plate:</b>	<b>W:</b> 24"	<b>D:</b> 12"
--------------------	---------------	---------------

<b>Weight:</b>	146 lbs.	<b>Capacity:</b>	1,200 lbs.
----------------	----------	------------------	------------

<b>Typically Ships:</b>	Freight, fully assembled
-------------------------	--------------------------



*Expect more. get more.*  
FROM GRANITE INDUSTRIES

- Exceptional quality and service on every product.
- Professional grade designs by in house engineers.
- Industry leading warranties.
- Family owned and operated in the USA.

## MADE IN THE USA GUARANTEE



Our American made products are engineered, manufactured and assembled in Archbold, OH using USA made steel.



**GRANITE  
INDUSTRIES**

877-447-2648  
graniteind.com  
americancartandrack.com

Scan the QR code to view more products.

