



Tree add on shown installed on X-Country wagon

2,000 LB



OUR CARTS
HAUL
MORE

PROUDLY
MADE IN THE
USA



BUILT
HEAVY DUTY
TO OUTLAST
OTHERS



THREE
YEAR
LIMITED
WARRANTY

FEATURES

- 2 trees for more hauling options (cart not included)
- Compatible with all X-Country wagons
- 2,000 lb capacity, evenly distributed

STANDARD AMERICAN CART FEATURES

- **Made in the USA**
Hand crafted at our Ohio plant.
- **Heavy-duty comes standard**
American Carts are all built to heavy duty specs
- **Powder coated finish**
Protects the steel and provides a lasting finish
- **Steel construction**
Built from American sourced steel
- **Easy to operate**
Designed to get work done with less muscle strain and simple operation.
- **Ready to ship**
in stock and ready to ship
- **Three Year Limited Warranty**

AMERICAN CART & RACK

MANUFACTURED BY GRANITE INDUSTRIES

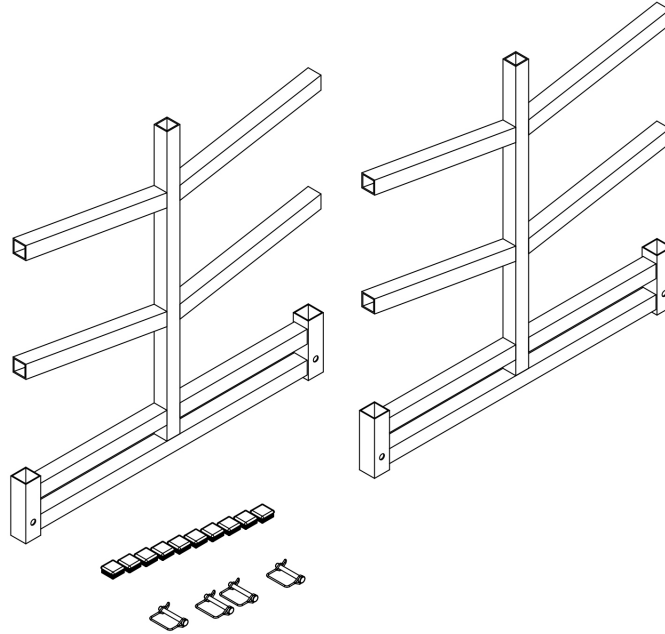

Dimensions: **W:** 35" **D:** 1.5" **H:** 33"

Weight: 32 lbs. ea **Capacity:*** 2,000 lbs.

Typically Ships: Freight, fully assembled

*Evenly distributed weight