

AMERICAN CART & RACK

MANUFACTURED BY GRANITE INDUSTRIES

67125-0505
CHAIR DOLLY WITH TALL
REMOVABLE SIDES

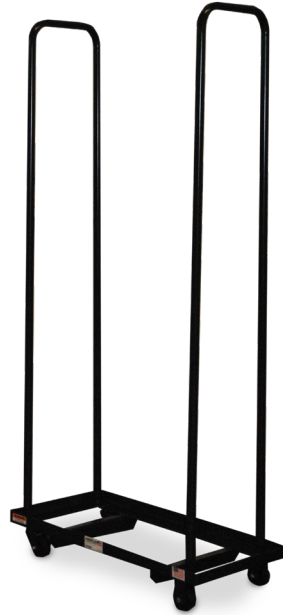

500 LB



OUR CARTS
HAUL
MORE

PROUDLY
MADE IN THE
USA



BUILT
HEAVY DUTY
TO OUTLAST
OTHERS



THREE
YEAR
LIMITED
WARRANTY

FEATURES

- Holds 50 Samsonite style poly folding chairs
- Removable end rails for easy storage
- Rails measure 15" wide outside to outside
- 3" plastic casters 2 fixed, 2 swivel
- 500 lb capacity

STANDARD AMERICAN CART FEATURES

- **Made in the USA**
Hand crafted at our Ohio plant.
- **Heavy-duty comes standard**
American Carts are all built to heavy duty specs
- **Powder coated finish**
Protects the steel and provides a lasting finish
- **Steel construction**
Built from American sourced steel
- **Easy to operate**
Designed to get work done with less muscle strain and simple operation.
- **Ready to ship**
in stock and ready to ship
- **Three Year Limited Warranty**



877.447.2648

GraniteInd.com | AmericanCartAndRack.com

AMERICAN CART & RACK

MANUFACTURED BY GRANITE INDUSTRIES

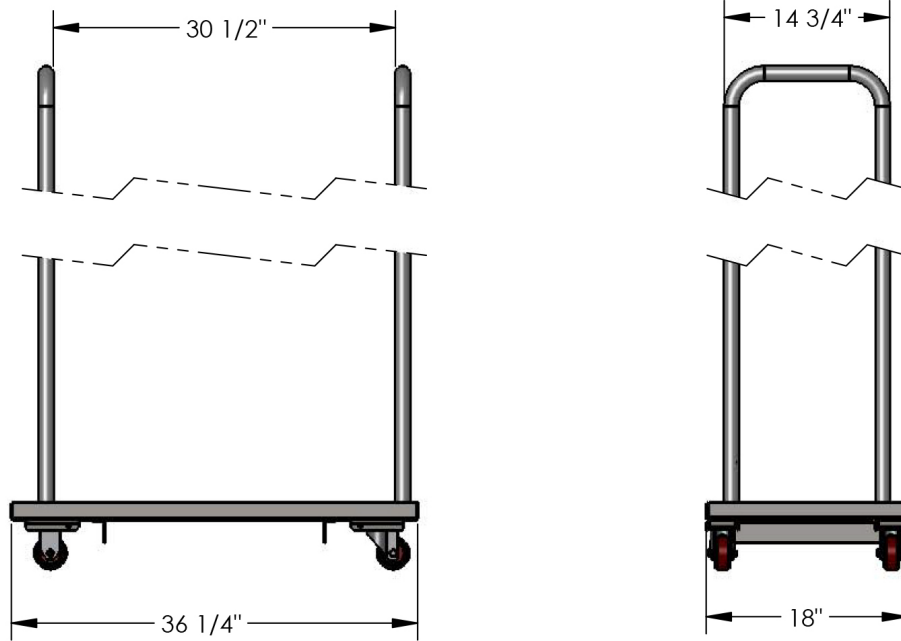

Dimensions:	W: 18"	D: 36"	H: 74"
Weight:	49 lbs.	Capacity:	500 lbs.
Typically Ships:	Freight; minimal assembly required		