



600 LB



OUR CARTS  
HAUL  
MORE

PROUDLY  
MADE IN THE  
USA



FLAT  
FREE  
TIRES



THREE  
YEAR  
LIMITED  
WARRANTY

## FEATURES

- 3/4" axle
- 10" flat free wheels with steel hubs
- Fold down wheels with 4" casters
- Integrated tie strap (gray)
- E-Track ratchet system, includes (1) 12' E-Strap (yellow)
- Dual steel stair-crawlers
- 600 lb capacity

## STANDARD AMERICAN CART FEATURES

- **Made in the USA**  
Hand crafted at our Ohio plant.
- **Heavy-duty comes standard**  
American Carts are all built to heavy duty specs
- **Powder coated finish**  
Protects the steel and provides a lasting finish
- **Steel construction**  
Built from American sourced steel
- **D-Brackets**  
One piece design supports the axle and load better than the competition
- **3/4" Axle**  
Industry leading axle size for maximum strength.
- **Easy to operate**  
Designed to get work done with less muscle strain and simple operation.
- **Ready to ship**  
in stock and ready to ship
- **Three Year Limited Warranty**



Shown with gray tie strap and yellow E-Strap.



# AMERICAN CART & RACK

MANUFACTURED BY GRANITE INDUSTRIES

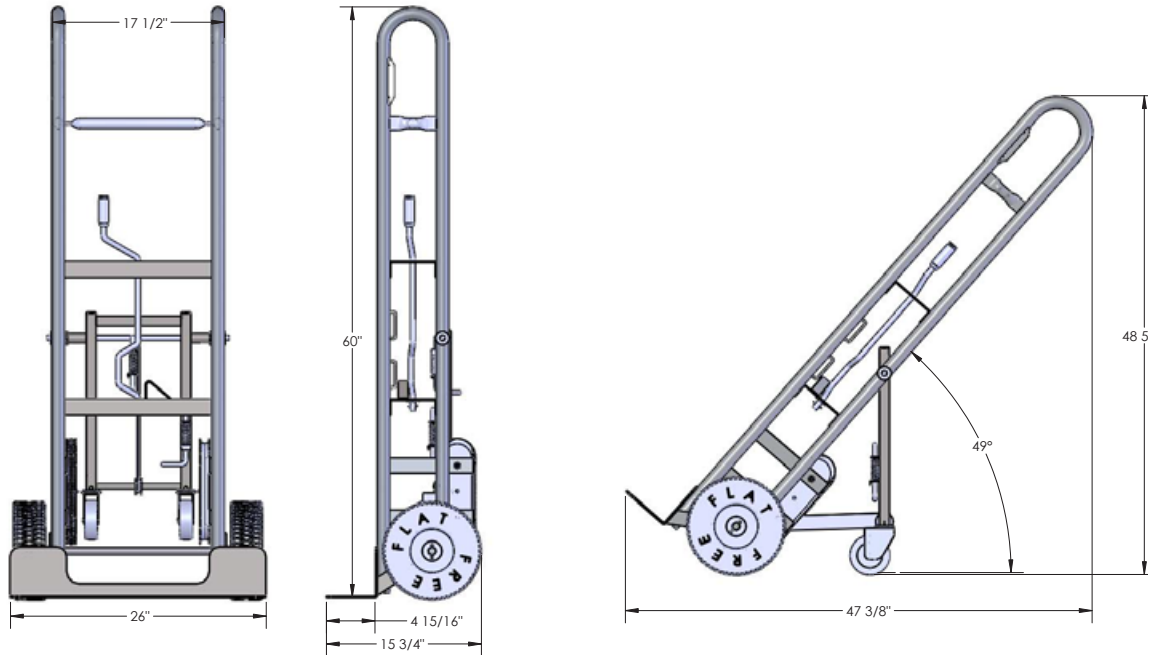

**Dimensions:**    **W:** 26"    **D:** 48"    **H:** 49"

**Foot Plate:**    **W:** 26"    **D:** 5"

**Weight:**        80 lb        **Capacity:** 600 lb

**Typically Ships:** Freight; fully assembled

\*Measurements taken on 4 wheels

## ESTIMATED PALLETED SPECS

**Dimensions:**    **W:** 24"    **D:** 40"    **H:** 66"

**Weight**            100 lbs.



*Expect more. get more.*  
FROM GRANITE INDUSTRIES

- Exceptional quality and service on every product.
- Professional grade designs by in house engineers.
- Industry leading warranties.
- Family owned and operated in the USA.

## MADE IN THE USA GUARANTEE



Our American made products are engineered, manufactured and assembled in Archbold, OH using USA made steel.



**GRANITE  
INDUSTRIES**

877-447-2648  
graniteind.com  
americancartandrack.com

Scan the QR code to view more products.

