



1,500 LB
OUR CARTS
HAUL
MORE

PROUDLY
MADE IN THE
USA

BUILT
HEAVY DUTY
TO OUTLAST
OTHERS

3yr
THREE
YEAR
LIMITED
WARRANTY

FEATURES

- Designed for storing tent stakes.
- Stack up to 3 high
- E-Track ratchet system, 12' E-Strap sold separately (PI-11-0212)
- 1,500 lb capacity

STANDARD AMERICAN CART FEATURES

- **Made in the USA**
Hand crafted at our Ohio plant.
- **Heavy-duty comes standard**
American Carts are all built to heavy duty specs
- **Powder coated finish**
Protects the steel and provides a lasting finish
- **Steel construction**
Built from American sourced steel
- **Easy to operate**
Designed to get work done with less muscle strain and simple operation.
- **Ready to ship**
in stock and ready to ship
- **Three Year Limited Warranty**



Pictured with rolling base 59337

AMERICAN CART & RACK

MANUFACTURED BY GRANITE INDUSTRIES

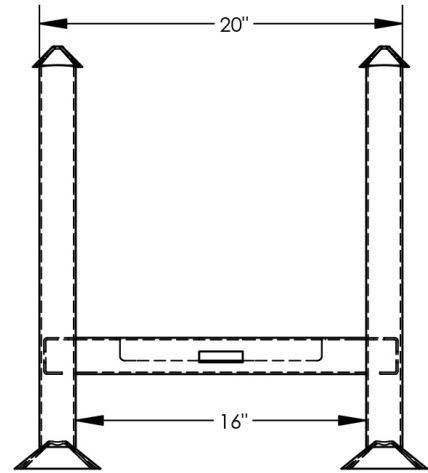
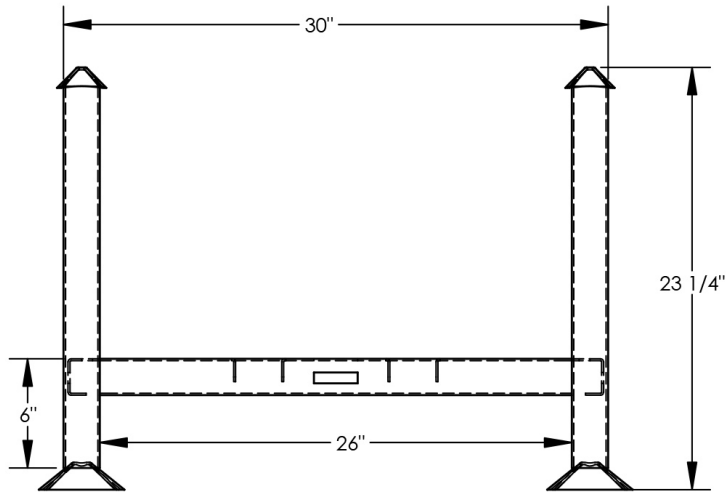

Dimensions:	W: 33"	D: 23"	H: 23"
Inside:	W: 26"	D: 16"	H: 15"
Weight:	46 lbs.	Capacity:	1,500 lbs.

*Weight taken with casters.