



GRANITE
INDUSTRIES

A M E R I C A N
C A R T & R A C K

MANUFACTURED BY GRANITE INDUSTRIES

MEGA HAULER

WITH **FOLD DOWN REAR WHEELS**
INSTRUCTION MANUAL



67265

Revised: JULY 2017

CONTENTS

Specs	3
Parts Diagram	4
Assembly	5

TOOLS NEEDED

- None

MADE IN THE USA GUARANTEE



Our American made products are engineered, manufactured and assembled in Archbold, OH using USA made steel.



Expect more. get more.
FROM GRANITE INDUSTRIES

- Exceptional quality and service on every single product.
- Professional grade designs by our in house engineers.
- Industry leading warranties.
- Family owned and operated in the USA.

To view more products from
American Cart & Rack
scan the QR code with your phone
or visit AmericanCartAndRack.com



WARRANTY

3 Year Limited Warranty. Carts, excluding any finishes, casters and wheels are warranted for three (3) years from date of original purchase. Casters and wheels are warranted for 90 days from date of original purchase. We will repair, without charge, any defect due to faulty material or workmanship. These warranties do not cover failures due to abuse, misuse, improper installation, accidental damage or when repairs or modifications have been made or attempted to be made by anyone other than Granite Industries. Any defective products that meet warranty specifications and Granite Industries approval, may be returned to the factory to be repaired or replaced free of charge. (Granite Industries will pay to ship replacement item(s) to the customer; however the customer is responsible for shipment of products to the factory.) This remedy is the sole remedy in contract, tort or otherwise, and Granite Industries is not liable for incidental, consequential or special damages. These warranties give you specific legal rights, and you may have other rights which vary from state to state. Should you have any questions, contact Granite Industries (Proof of purchase may be required).



**GRANITE
INDUSTRIES**

**Customer Service
877-447-2648
M-F, 8am - 5pm EST**

SPECS

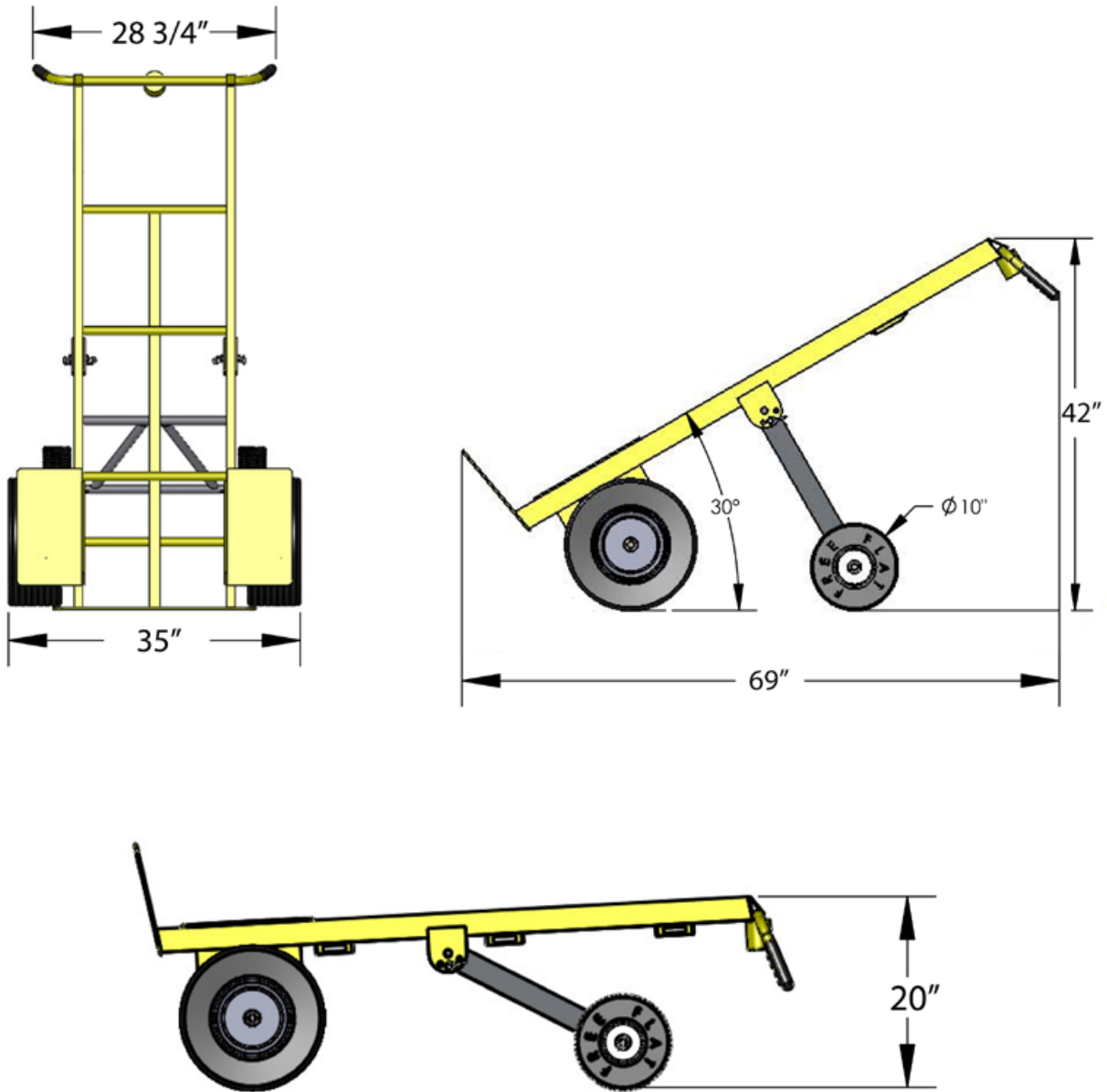

Overall Dimensions:	W: 35"	D: 69"	H: 42"
Foot Plate:	W: 24"	D: 12"	
Weight:	146 lbs.	Capacity:	1000 lbs.

*Measurements taken on 4 wheels.

PARTS DIAGRAM

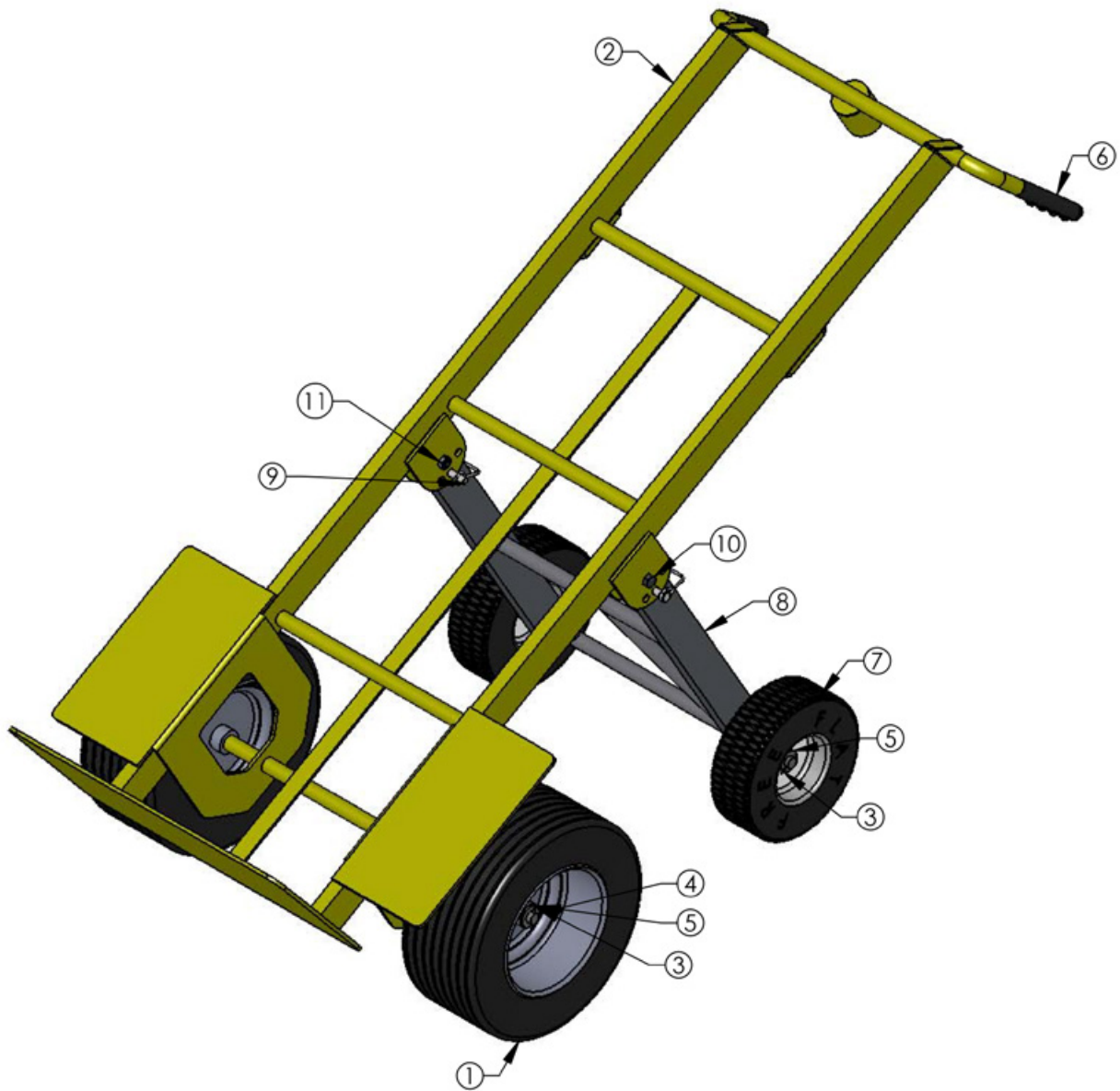

ITEM NO	QTY	PART NO	DESCRIPTION	
1	2	PI-06-0048	16" Wheel with Steel Hub	
2	1	MI-12-4624	Mega Hauler Cart Body	
3	4	PI-01-0226	1-1/4" Cotter Pin	
4	1	MI-04-0537	30-1/2" Axle Rod	
5	4	PI-01-0229	3/4" Washer	
6	2	PI-04-0109	Hand Grip	
7	2	PI-06-0115	10" Wheel with Steel Hub	
8	1	MI-12-4625	Rear Axle Assembly	
9	2	06057	3" Snap Pin	
10	2	PI-01-0264	1/2" Hex Bolt	Use 3/4" wrench & socket
11	2	PI-01-0121	1/2" Nut	Use 3/4" wrench & socket