



MULTI MOVER

INSTRUCTION MANUAL



67246-75

CONTENTS

Specs	3
Parts Diagram	4
Assembly	5

TOOLS NEEDED

- Needle Nose Pliers
- Box Cutters / Utility Knife

STANDARD ON ALL AMERICAN CART PRODUCTS

Made in the USA

Hand crafted at our Ohio plant.

Heavy-duty comes standard

American Carts are all built to heavy duty specs

Flat-free tires

10 inch closed-cell tires that will never go flat

Powder coated finish

Protects the steel and provides a lasting finish

D-Brackets

One piece design holds the axle in place and supports the load

Steel construction

Built from American sourced steel

Easy to operate

Designed to get work done with less muscle strain and simple operation

WARRANTY

3 Year Limited Warranty. Carts, excluding any finishes, casters and wheels are warranted for three (3) years from date of original purchase. Casters and wheels are warranted for 90 days from date of original purchase. We will repair, without charge, any defect due to faulty material or workmanship. These warranties do not cover failures due to abuse, misuse, improper installation, accidental damage or when repairs or modifications have been made or attempted to be made by anyone other than Granite Industries. Any defective products that meet warranty specifications and Granite Industries approval, may be returned to the factory to be repaired or replaced free of charge. (Granite Industries will pay to ship replacement item(s) to the customer; however the customer is responsible for shipment of products to the factory.) This remedy is the sole remedy in contract, tort or otherwise, and Granite Industries is not liable for incidental, consequential or special damages. These warranties give you specific legal rights, and you may have other rights which vary from state to state. Should you have any questions, contact Granite Industries (Proof of purchase may be required).



GRANITE
INDUSTRIES

Customer Service

877-447-2648

M-F, 8am - 5pm EST

MULTI MOVER SPECS

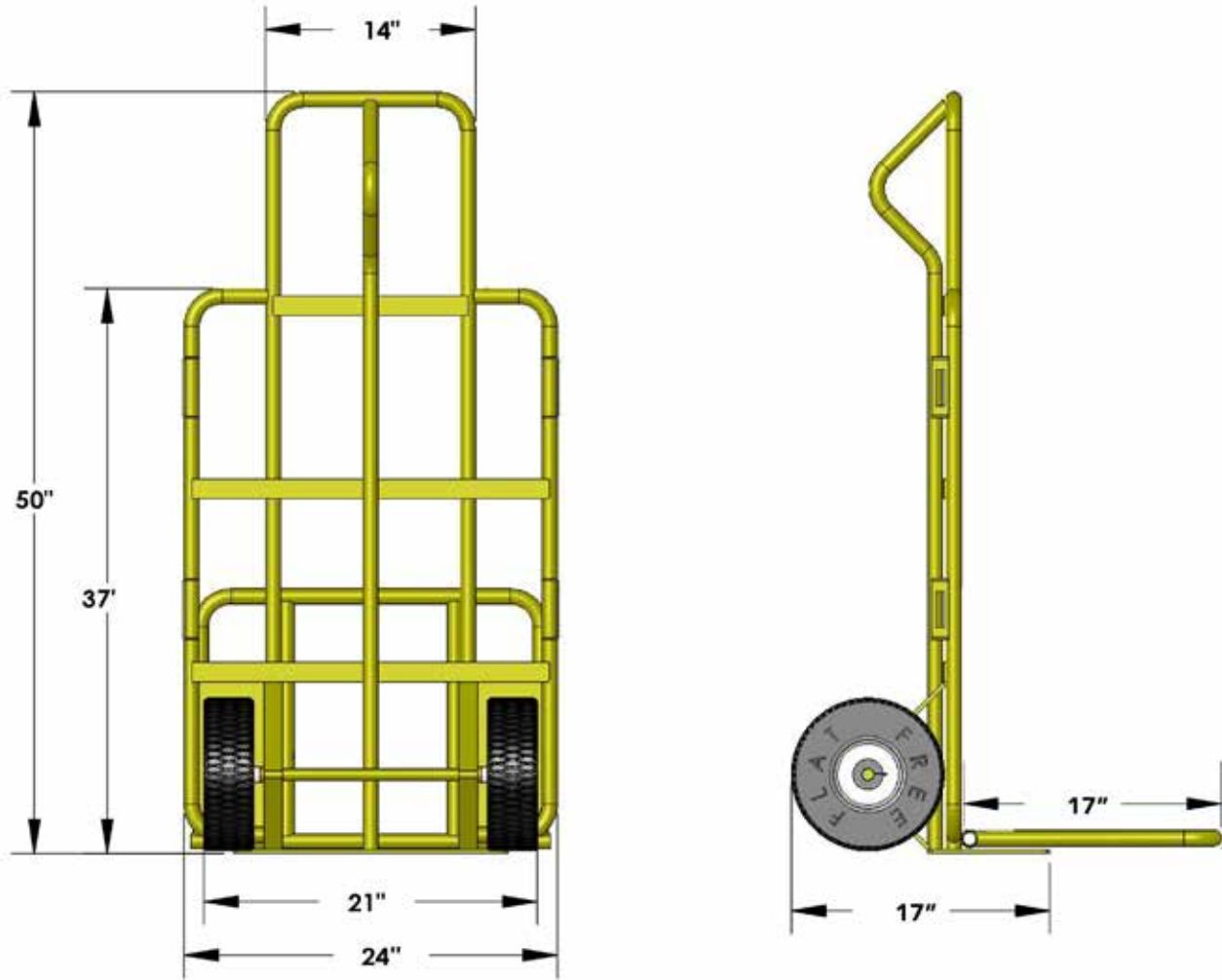

Overall Dimensions:	W: 24"	D: 28"	H: 50"
Foot Plate:	W: 23"	D: 17"	
Weight:	59 lbs.	Capacity:	600 lbs.

*Measurements taken with folding foot plate open

PARTS DIAGRAM

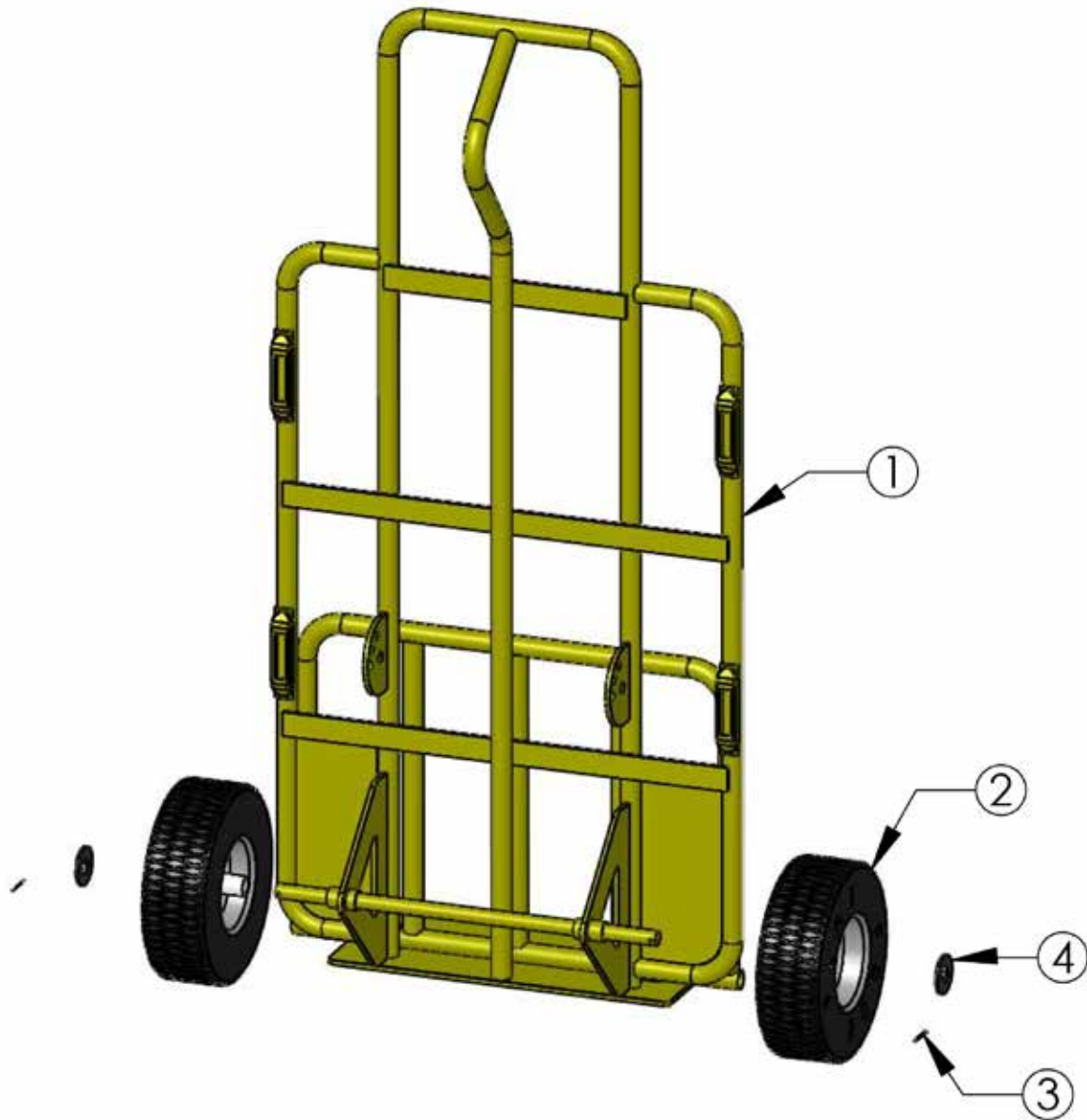

ITEM NO	QTY	PART NO	DESCRIPTION
1	1	MI-12-4618	MULTI MOVER CART BODY
2	2	PI-06-0115	10" STEEL HUB WHEEL
3	2	PI-01-0226	1-1/4" COTTER PIN
4	2	PI-01-0451	3/4" WASHER

FRONT WHEEL ASSEMBLY

COMPONENTS		
ITEM NO	QTY	DESCRIPTION
1	1	Multi Mover Cart Body
2	2	10" Flat Free Steel Hub Wheel
3	2	1-1/4" Cotter Pin
4	2	3/4" Washer

TOOLS		
Needle Nose Pliers		



1 Insert the wheels onto the front axle located towards the bottom of the Multi Mover. The offset side of the wheel should be facing the cart body.



2 Slide the washer onto the axle.



3 Insert the cotter pin and secure it by bending both ends outward with a **needle nose pliers**.



Your Multi Mover is now fully assembled.



GRANITE INDUSTRIES
595 EAST LUGBILL ROAD
877-447-2648
SUPPORT@GRANITEIND.COM