



2,000 LB



OUR CARTS
HAUL
MORE

PROUDLY
MADE IN THE
USA



BUILT
HEAVY DUTY
TO OUTLAST
OTHERS



THREE
YEAR
LIMITED
WARRANTY

FEATURES

- Keep your workplace clutter free
- 8" casters; 4 swivel with locks
- Stack up to 3 high, do not exceed 2,000 lbs on casters

STANDARD AMERICAN CART FEATURES

- **Made in the USA**
Hand crafted at our Ohio plant.
- **Heavy-duty comes standard**
American Carts are all built to heavy duty specs
- **Powder coated finish**
Protects the steel and provides a lasting finish
- **Steel construction**
Built from American sourced steel
- **Easy to operate**
Designed to get work done with less muscle strain and simple operation.
- **Ready to ship**
in stock and ready to ship
- **Three Year Limited Warranty**

AMERICAN CART & RACK

MANUFACTURED BY GRANITE INDUSTRIES

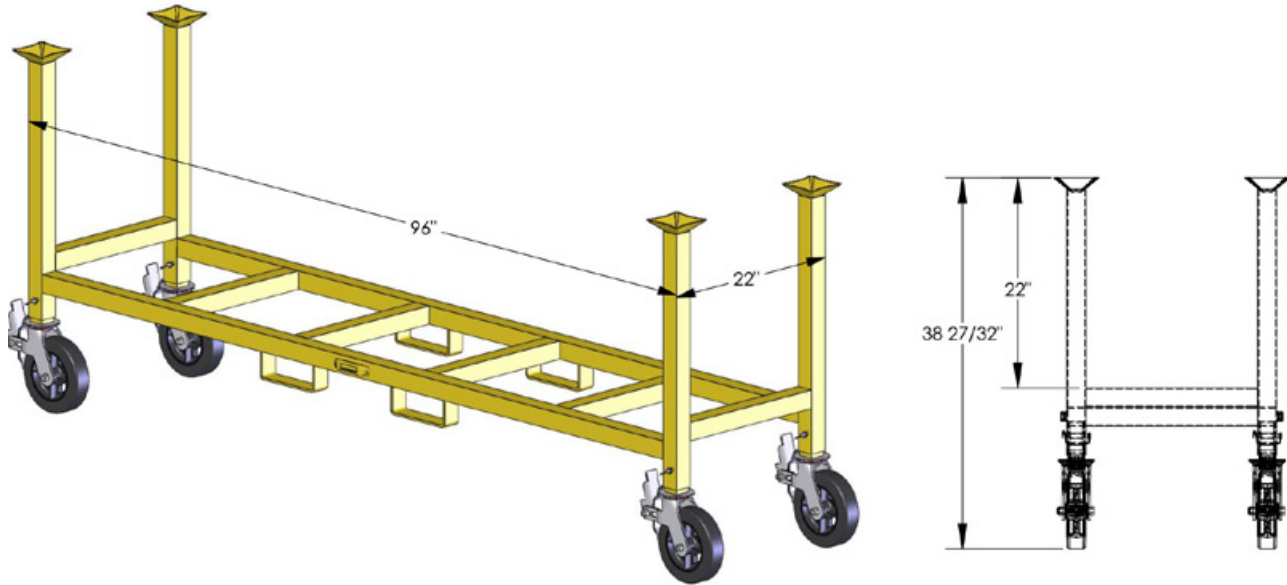

Dimensions:	W: 98"	D: 25"	H: 39"
--------------------	---------------	---------------	---------------

Storage Area:	W: 92"	D: 18"	H: 23"
----------------------	---------------	---------------	---------------

Weight:*	155 lb	Capacity:	2,000 lb
-----------------	--------	------------------	----------

Typically Ships:	Freight; minimal assembly required		
-------------------------	------------------------------------	--	--

*Weight taken with casters.